

ULTRA

PRODUCT MANUAL



W www.saferoads.com.au
T +61 3 5945 6600
E sales@saferoads.com.au



Version 2.3
February 2018

Contents

Preface	2
Introduction	2
Crash Tests	3
System Design	4
Installation Examples	6
Installation Drawing	7
Installation Procedure.....	8
Repairs and Maintenance	11
Inspection and Test Plan	12



W www.saferoads.com.au
T +61 3 5945 6600
E sales@saferoads.com.au

Version 2.3
February 2018
Page 1

Preface

Proper design, installation and maintenance of the Omni-Stop Ultra Security Bollard is essential to ensure maximum performance.

It is critical for installers of the Omni-Stop Ultra Security Bollard to be fully familiar with this manual. Take the time to review this manual thoroughly before performing the necessary work.

If more information is required please contact Saferoads:

Website: www.saferoads.com.au

Australia: 1800 060 672

USA: 859 469 0364

International: +61 3 5945 6600

Email: sales@saferoads.com.au

Introduction

Saferoads Omni-Stop Ultra Security Bollard has been successfully crash tested to confirm it can stop a 3500lb/1600kg pickup travelling at 30mph/50kmh*. The bollard must be installed in accordance with this product manual and the enclosed minimum footing requirements.

The test vehicle impacted the bollard in the centre of the vehicle, the forward displacement of the structural elements of the vehicle during the impact was 30in/440mm from the centre of the bollard, when the footing is surrounded by 250mm concrete.

* Refer to NATA test 21062-01 on 22/5/2017

Identification

The Omni-Stop Ultra Security Bollard has been crash tested, each bollard displays an identification sticker as per the below image.



W www.saferoads.com.au
T +61 3 5945 6600
E sales@saferoads.com.au

Version 2.3
February 2018
Page 2

Crash Tests

The Omni-Stop Ultra Security Bollard was crash tested in May 2017, for full details refer to NATA test reports 21062-01.

In accordance with **AS3845.2 Clause 8.4(c)**, elements of the vehicle penetrated 18in/440mm past the bollard centre line during impact, measured at the vehicle bumper height, with consideration for movement of the bollard during impact.

See below extract from the test report, where the vehicle penetrated 18in/440mm past the centre of the bollard during impact. It would be desirable for designers to allow a conservative 20in/500mm past the centre of the bollard for the design clear zone.

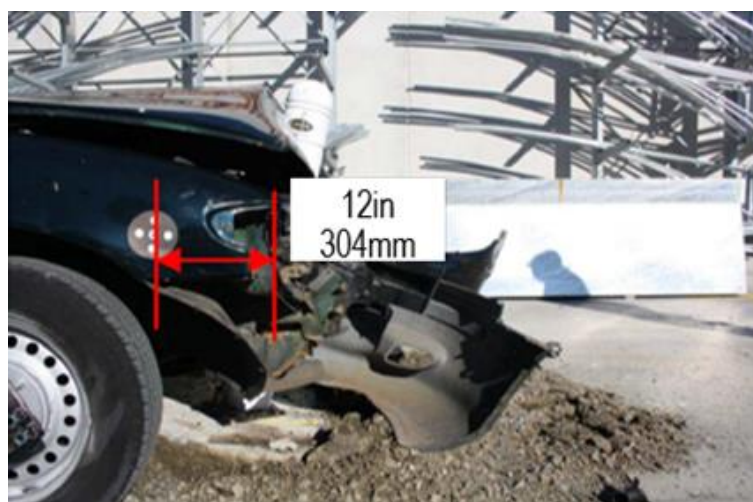

System Design

Note: A site-specific risk assessment should be completed at each site to ensure the positioning of the bollards meets the design brief and are fit for purpose.

Crash testing has shown that the vehicle penetrates past the bollard during an impact. The figure below shows the recommended clear zone (20in/500mm) behind the centre of a bollard in the direction of the impacting vehicle.

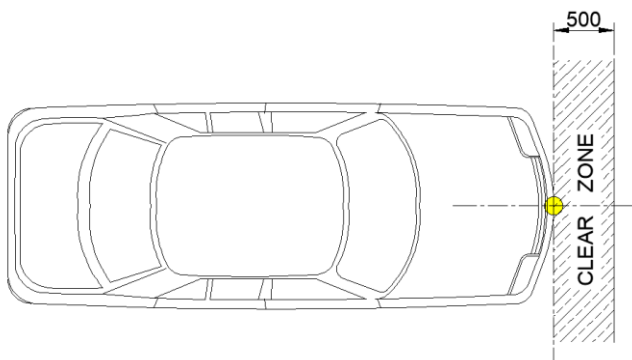

When designing bollard arrays, or strings, the direction of all potential impacting vehicles needs to be considered to ensure the design is fit for purpose.

Typically, a minimum of 2 bollards are required to protect an object as vehicles can impact the bollard from varying angles. A single bollard has limited scope as vehicles can pass the bollard on either side.

One bollard may reduce the potential of vehicle impacts on the corner of a bridge abutment, however the below layout is recommended to ensure the abutment is properly protected.

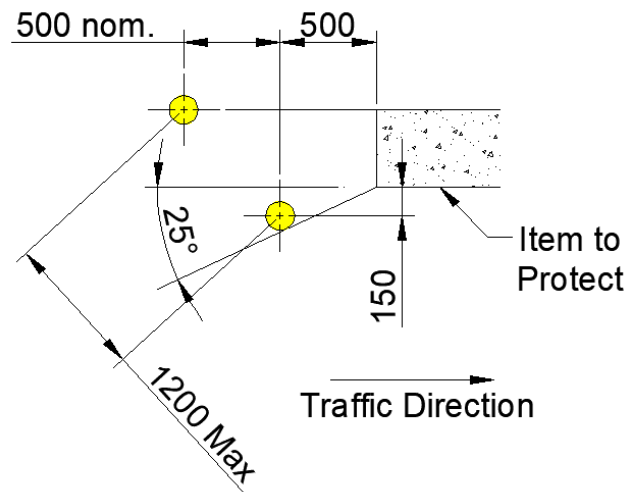

Note the 20in/500mm clear space between the centre of the bollards and the “protected item”. The potential angle of impact is set at 25 degrees, this can be adjusted as required by the designer, considering the likely angle of impact at the site.

The below figure shows the recommended minimum spacing of 50in/1350mm centres to prevent small cars penetrating a string of bollards when impacting perpendicular to the string. This is common when strings of bollards are installed at the end of a “T” intersection.

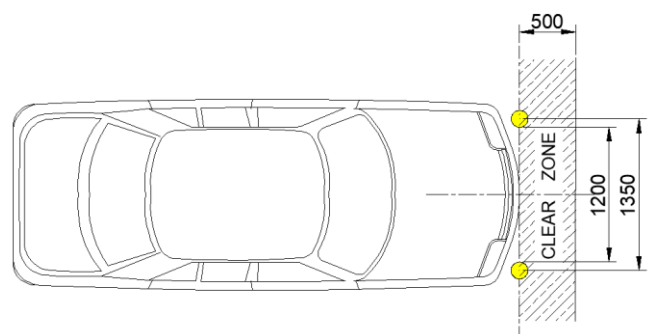

Note at 6.5ft/2000mm bollard spacing at 25° impact angle, the clear zone extends 36in/908mm perpendicular to the string of bollards. While the potential for vehicles to breach the string of bollards would follow a saw tooth pattern, the 36in/908mm clear zone offset should be applied to the entire length of the bollard string.

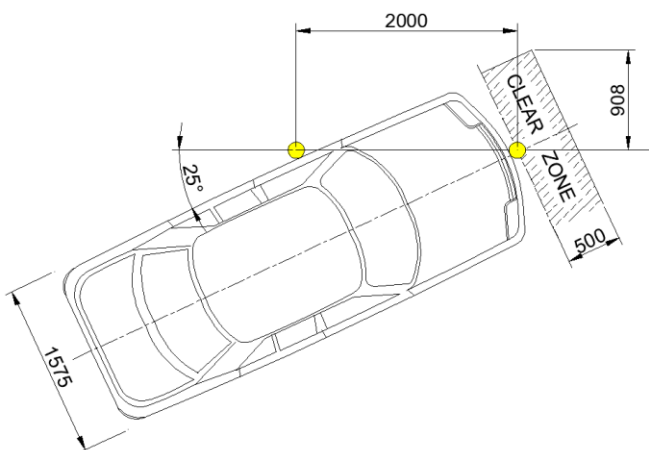

The spacing of the bollards can be altered depending on the design impact angle and allowable clear zone behind the string of bollards.

It is recommended that the centre to centre spacings be a maximum of 100in/2500mm.

The figures below show how the clear zone is reduced to 17in/431mm if the design impact angle can be reduced to 15 degrees, compared to 28in/717mm where the design impact angle was 25 degrees. Both examples have the same bollard spacing at 60in/1500mm.

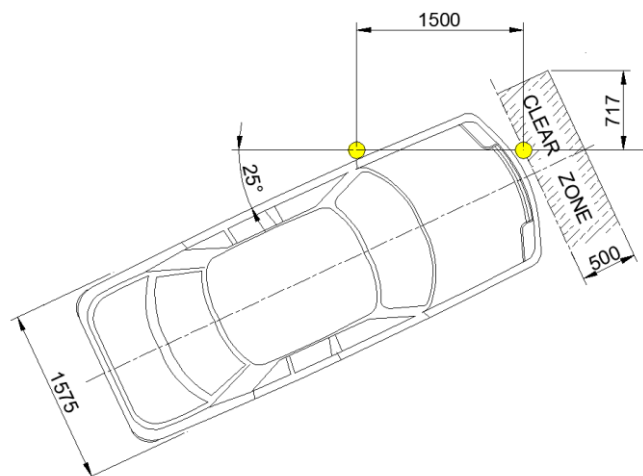
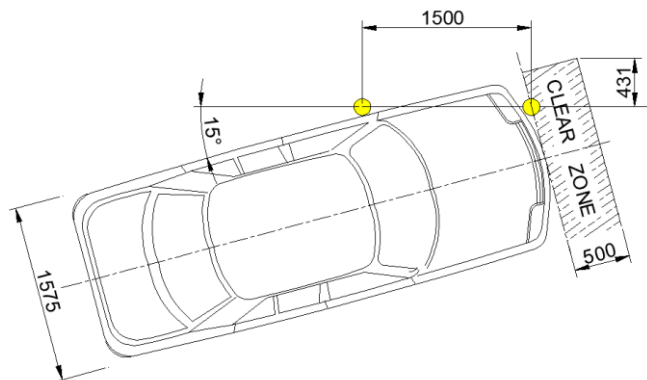

Installation Examples

See below examples of Omni Stop Bollard Installations.



The Omni Stop Ultra Security Bollard can be fitted with a lifting ring to enable the bollards to be lifted out of the footing when used in a work zone. An Omni Stop footing cap is placed into the sleeve to allow for vehicles and pedestrians to traverse safely.



W www.saferoads.com.au
T +61 3 5945 6600
E sales@saferoads.com.au

Version 2.3
February 2018
Page 6

Installation Drawing

Item 1 – Reinforcement cage assembly including
Bollard Tube receiver

Item 2 – 5000PSI/32MPa concrete footing,
28in/700mm dia. X 40in/1000mm deep

Item 3 – 55in/1400mm long “Omni” pipe plus domed
cap, 6in/150mm nominal O.D.

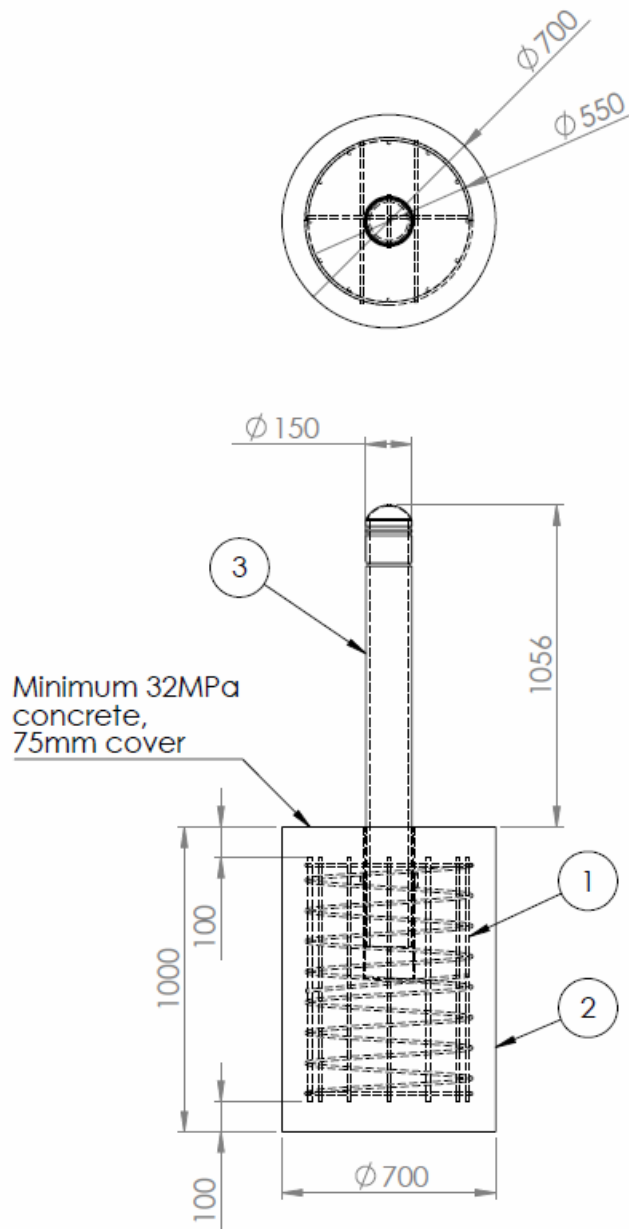

Installation Procedure

Important note:

Saferoads OMNI-STOP Ultra Security Bollard has been crash tested and can stop a 3500lbs/1600kg vehicle travelling at 30mph/50kph. It is important that the surrounding soil has sufficient strength to support the footing during a design impact. The minimum specification for the surrounding soil is that it should be a cohesive soil with a minimum Undrained Shear strength of 100kPa. A simple Dynamic Cone Penetrometer (DCP) test can be conducted, a minimum average of 2 blows per 2in/50mm is required.

Installation outside of these conditions may be possible, but a geotechnical engineer should be engaged to recommend appropriate design.

Before commencing ensure that you have had all services located and clearly identified using “Dial Before You Dig” or “Before You Dig Call 811”. Ensure you complete the Inspection and Test Plan (ITP).



Tools Required:

- Auger and or digging tools
- String line
- Spirit level
- Reo spacers
- 5000PSI/32MPa concrete
- Pencil vibrator
- 6in/150mm x 57in/1450mm light galvanised pipe

Mark out hole centres as per site design. If installing multiple bollards use a string-line to check they are in a straight line.



Auger or manually dig a minimum 28in/700mm diameter x 40in/1000mm deep hole.



W www.saferoads.com.au
T +61 3 5945 6600
E sales@saferoads.com.au

Version 2.3
February 2018
Page 8

Place 4 reinforcement spacers under the cage to allow the reinforcement cage to sit clear of the sub-soil.



Use a spirit level to ensure that the reinforcement cage assembly is correctly positioned.



Note: using a 6in/150mm x 57in/1450mm light weight galvanised pipe placed into the cage to check that the bollards will be vertical may assist.

Insert the Omni-Stop Ultra Security Bollard reinforcement cage, ensuring that the cage is at equal distance from the edges of the hole. Also ensure the top of the sleeve is level with the finished concrete surface.

Pour concrete into the space surrounding the reo cage to approximately 12in/300mm and then re-check levels. (Concrete must be 5000PSI/32MPa).



Fill the remainder of the hole with concrete. Ensuring that the application of concrete does not move the reo cage out of position.



The concrete should be vibrated with a pencil vibrator to settle the concrete and remove air pockets.

Be careful when pouring concrete that the Omni-Stop Ultra Security Bollard cage is not moved from its intended location, or level.

Warning: the performance of the Omni-Stop Ultra Security Bollard may be affected by incorrect installation.

Finish off by screeding the concrete surface and if applicable replace pavers around installed bollard.



Note: If paving is to be placed over the top of the footing, the excavation must be deep enough to ensure that the concrete footing is minimum 40in/1000mm deep and 28in/700mm diameter.

Sweep up any excess dirt or debris from the site.



Ensure you have completed the Inspection and Test Plan (ITP) for the Omni-Stop Ultra Security Bollard for each installation you have completed.

Repairs and Maintenance

In the event of an impact to the Omni Stop Ultra Security Bollard ensure that a visual inspection is undertaken at the earliest opportunity. If the bollard is marked or scuffed then there is a high probability that the bollard has been impacted. The bollard can sustain low speed impacts without compromising the system.



Check that the bollard is still vertical, if the bollard is not vertical the footing may have rotated in the ground or the bollard may have been bent by an over capacity impact such as a truck. The bollard may need to be removed from the footing to assess if the pipe is still straight.

A closer visual inspection of the footing will be required to identify any cracking or breakage. Broken pavers are a tell-tale sign of footing damage.



If there is damage then the footing will need to be removed and replaced.

If the bollard is still straight then it is fit to be reused in a new footing.

Installation of a new 5000PSI/32MPa concrete footing with reinforcement cage will need to be completed following the same procedure as the installation instruction outlined in this manual.

Warning: the Omni Stop Ultra Security Bollard may not perform to expectations if the integrity of the pipe bollard, concrete footing or soil support to the footing has been undermined by a prior impact.



Inspection and Test Plan

Date:	Site:		Client Initials	Installer Initials
Item No.	Activity	Acceptance Criteria	W/H/V /M/R	Verifying Authority
1	Installation location	Confirmation from client as to location, orientation and spacing's	H	Client + Installer
2	Locate underground services	Confirmation from client that area is clear from underground services or that all have been located and marked out clearly	H	Client + Installer
3	Hole for foundation	Hole to be 28in/700mm wide x 40in/1000mm deep	M	Installer
4	Concrete	Concrete to be minimum 5000PSI/32MPa	M	Installer
5	Alignment	Check bollards are aligned in a row	M	Installer
6	Orientation	Check bollard(s) are plumb	V	Installer
7	Paint condition	Check bollards for paint touch ups after install	V	Installer
8	Clean up	Tidy site before departure	V	Installer
Work on this section is completed to specified requirements			R	Client
H = Hold Point, M = Measure, R = Review Documentation, V = Visual Inspection, W = Witness				
Saferoads Pty Ltd		Form QP04-056-SA	Authorized by: Casey McMaster	Issue 3
				13/07/2023

